

GT40
A = 10 mm

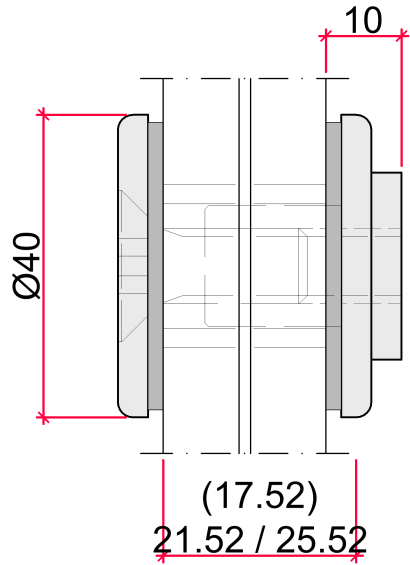

GT40
A = 25 mm

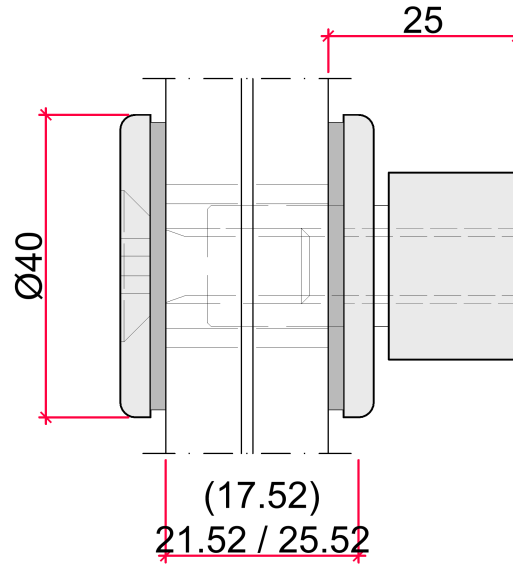

GT40
A = 35 mm

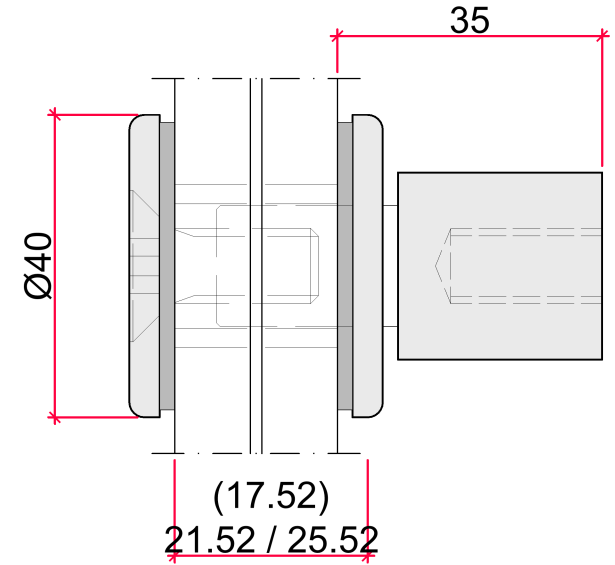

GT40
A = 15 mm

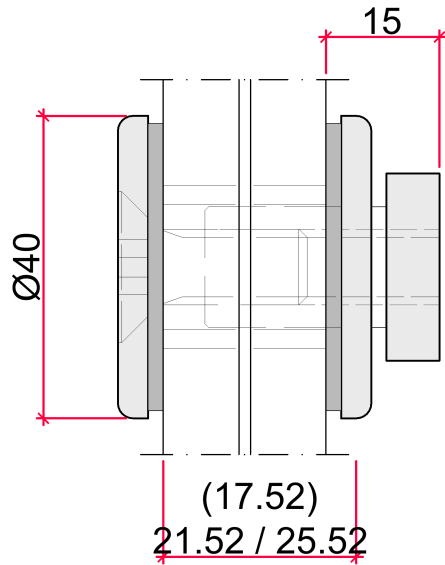

GT40
A = 30 mm

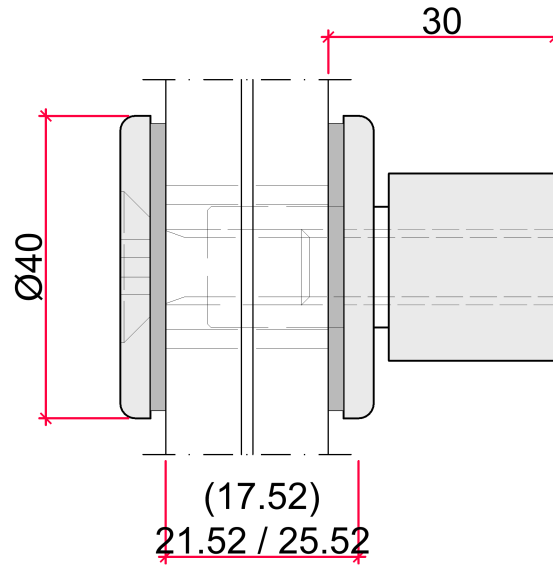

GT40
A = 40 mm

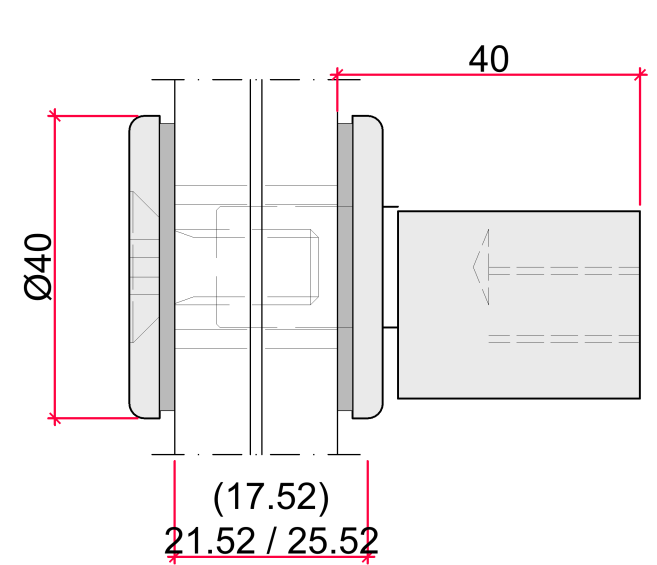

GT40
A = 45 mm

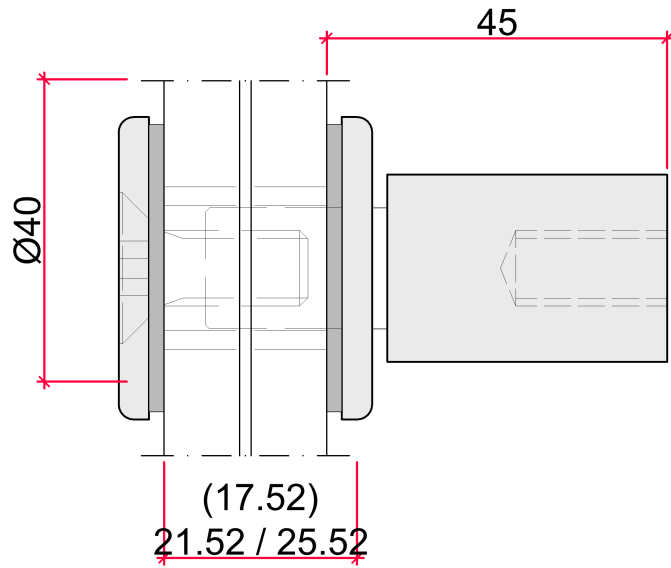

GT40
A = 55 mm

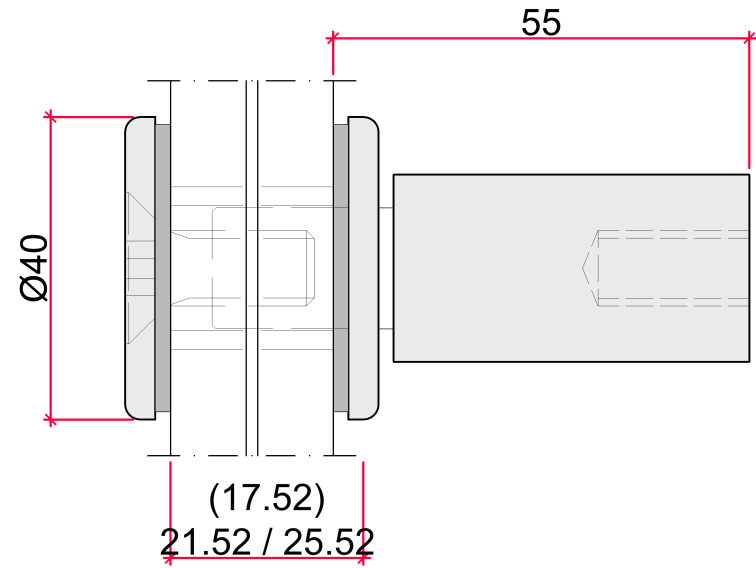

GT40
A = 50 mm

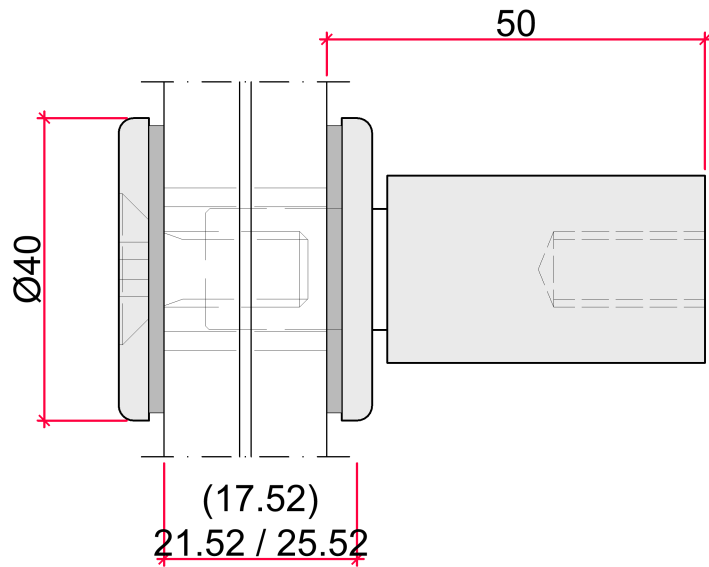

GT40
A = 60 mm

